

---

**DODGE<sup>®</sup> GEAR COUPLINGS**  
**THE POWER-DENSE,  
HIGH-TORQUE GEAR COUPLING**



# The Power-Dense, High-Torque Gear Coupling

---

The new DODGE® Gear Coupling (DGF) offers unmatched performance and proven reliability.

---

## Quality Manufacturing

- X High-quality steel
- X Larger tooth profile provides additional service factor
- X Good inherent balance
- X Proven O-ring seal design
- X Machined flanges and gasket for improved sealing
- X High-grade fasteners

## Performance Benefits

- X High torque rating allows for coupling downsizing
- X Versatile design permits interchangeable half couplings
- X Low backlash (well suited for reversing applications)
- X Crowned tooth profile for longer life and improved performance

## DODGE Benefits

- X Coupling solutions for any application  
Choose from DODGE® coupling family: Gear (DGF), PARA-FLEX®, GRID-LIGN®, D-FLEX, Rigid, and Fluid - all available from stock.
- X Combine DODGE® couplings with any DODGE® speed reducer for unmatched performance  
Choose from thousands of combinations to get a package tailored to meet your needs.
- X Years of application expertise  
DODGE engineers can help specify products to achieve maximum results from your equipment.

## PT WIZARD™ CD-ROM Resource Software Library

- X Features interactive single compact disk (a total reference source) that allows quick access DODGE product information and specific information on proper coupling selection.
- X Contains DODGE FIRST LINE(Drawing Template Library; the DODGE SOFTWARE( Product Selection Library; AutoCAD( dimensional DWG files; 32,000 parts numbers; and 300 installation manuals
- X Selects product drawing; transfers drawing into specifier's system; creates purchase orders; ensures fast service through EDI, fax, or E-mail



# Engineered for Improved Operation

---

Reliable O-ring design effectively seals against contaminants

Accessory kit  
• High grade features  
• Gasket for effective sealing

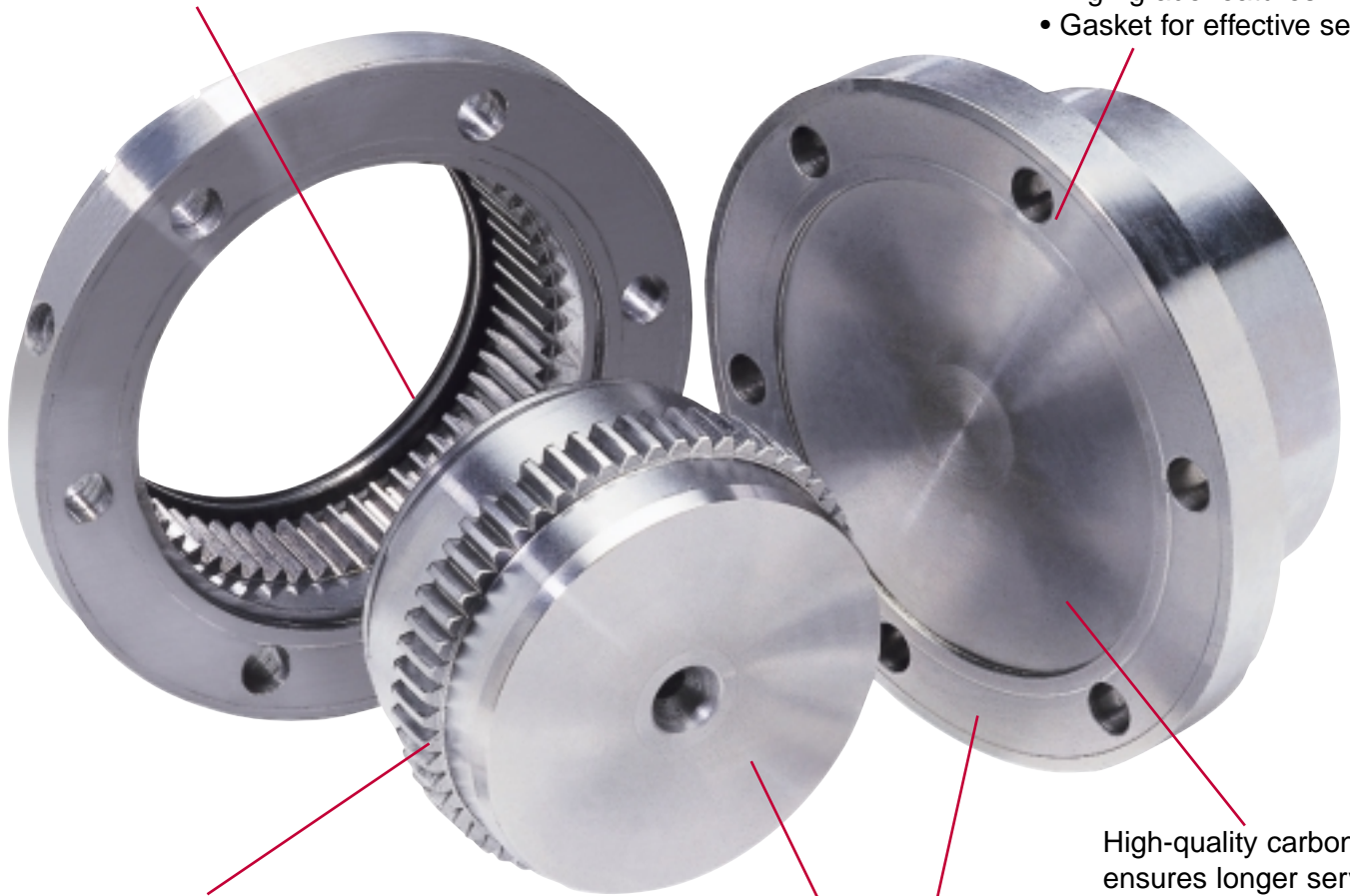

High-pressure angle provides large tooth base; results in high safety factor

Flexible, rigid hub styles available

High-quality carbon steel ensures longer service life

# Engineering/Technical

## Selection Methods DODGE Gear Couplings (DGC)

Two methods may be used in selecting a DODGE Gear Coupling: the HP/100 method or the torque method. In both cases, the following information is required for proper selection:

- \* application or type of equipment to be connected,
- \* horsepower or torque,
- \* RPM or coupling,
- \* shaft diameters,
- \* and shaft spacing.

Other information that may be used to refine your selection includes: system peak torque and frequency, hours/day of operation, special bore fits or tolerances, and space limitations.

### HP/100 Method

- Step 1** Obtain required Service Factor from Service Factor Table on Page 5.  
**Step 2** Determine the application HP per 100 RPM:

$$\text{HP/100 RPM} = \frac{\text{Motor HP} \times 100 \times \text{Service Factor}}{\text{Coupling RPM}}$$

- Step 3** From the Rating Table on Page 6, find a rating equal to or greater than the HP/100 RPM. Note coupling size from left-hand column.

**Step 4** Check maximum RPM capability.

**Step 5** Check maximum bore capacity. If maximum bore is exceeded, move to larger size with adequate bore, but be sure maximum RPM of coupling is not exceeded.

Note: If spring set motor brake is used, and brake HP is greater than prime mover, use brake HP in place of motor HP.

### Torque Method

**Step 1** Obtain required Service Factor (SF) from Service Factor Table on Page 5.

**Step 2** Determine torque required for application:

$$\text{Torque (in-lb)} = \frac{63025 \times \text{HP} \times \text{SF}}{\text{RPM}}$$

**Step 3** From the Rating Table on Page 6, find a rating equal to or greater than the torque. Note coupling size from left-hand column.

**Step 4** Check maximum RPM capability.

**Step 5** Check maximum bore capacity. If maximum bore is exceeded, move to larger size with adequate bore, but be sure maximum RPM of coupling is not exceeded.

Note: If system peak torque is known and is non-reversing, start at Step 3. If system peak torque is known and reversing, multiply by 2.0 and start at Step 3.

Information extracted from AGMA Standard 511.02 for bores through 6 inches.

Nominal Shaft Size		Interference Fit <sup>1</sup>			Clearance Fit <sup>2,3</sup>		
		Nominal Shaft Size Minus	Bore Tolerance Plus	Bore Tolerance Minus	Nominal Shaft Size Minus	Bore Tolerance Plus	Bore Tolerance Minus
-	1.5000	0.0010	0.0005	0.0000	0.0000	0.0010	0.0000
1.5000	2.0000	0.0020	0.0010	0.0000	0.0000	0.0010	0.0000
2.0000	3.0000	0.0020	0.0010	0.0000	0.0000	0.0015	0.0000
3.0000	4.0000	0.0030	0.0015	0.0000	0.0000	0.0015	0.0000
4.0000	5.0000	0.0035	0.0015	0.0000	0.0000	0.0020	0.0000
5.0000	6.0000	0.0040	0.0015	0.0000	0.0000	0.0020	0.0000
6.0000	7.0000	0.0050	0.0020	0.0000	-	-	-
7.0000	8.5000	0.0060	0.0020	0.0000	-	-	-
8.5000	10.0000	0.0070	0.0020	0.0000	-	-	-
10.0000	12.0000	0.0080	0.0020	0.0000	-	-	-
12.0000	13.0000	0.0090	0.0025	0.0000	-	-	-

Nominal Bore Size Over	Preferred Standard Keyway Dimensions <sup>4</sup>	Preferred Standard Key Dimensions <sup>4</sup>	Shallow Key Dimensions <sup>5</sup>	Shallow Keyway Dimensions <sup>5</sup>
0.3125	0.4375	3/32 x 3/64	3/32 x 3/32	-
0.4375	0.5625	1/8 x 1/16	1/8 x 1/8	-
0.5625	0.8750	3/16 x 3/32	3/16 x 3/16	-
0.8750	1.2500	1/4 x 1/8	1/4 x 1/4	-
1.2500	1.3750	5/16 x 5/32	5/16 x 5/16	-
1.3750	1.7500	3/8 x 3/16	3/8 x 3/8	-
1.7500	2.2500	1/2 x 1/4	1/2 x 1/2	1/2 x 1/8
2.2500	2.7500	5/8 x 5/16	5/8 x 5/8	5/8 x 3/16
2.7500	3.2500	3/4 x 3/8	3/4 x 3/4	3/4 x 3/16
3.2500	3.7500	7/8 x 7/16	7/8 x 7/8	7/8 x 1/4
3.7500	4.5000	1 x 1/2	1 x 1	1 x 1/4
4.5000	5.5000	1-1/4 x 5/8	1-1/4 x 1-1/4	1-1/4 x 1/4
5.5000	6.5000	1-1/2 x 3/4	1-1/2 x 1-1/2	1-1/2 x 1/4
6.5000	7.5000	1-3/4 x 3/4	1-3/4 x 1-1/2	1-3/4 x 1/4
7.5000	9.0000	2 x 3/4	2 x 1-1/2	2 x 3/8
9.0000	11.0000	2-1/2 x 7/8	2-1/2 x 1-3/4	2-1/2 x 3/8
11.0000	13.0000	3 x 1	3 x 2	3 x 3/8

1. Gear couplings are bored for interference fit unless other wise specified.
2. Clearance Fit not recommended for bore sizes exceeding 6 inches.
3. Based on AGMA Class 1 Clearance Fit.
4. Square key recommended through 6-1/2 inches, rectangular key is recommended for larger bores.
5. Shallow keyways are required for maximum bore capacity.

# Service Factors

		Application	Server Factor	Application	Server Factor
AREATOR	2.0	Rolls, Reversing	2	Converting Machine	1.25
AGGREGATE PROCESSING		Sawdust Conveyor	1.25	Couch	1.75
CEMENT, MINING KILNS; TUBE, ROD, and BALL MILLS		Slab Conveyor	1.75	Cutter, Felt Whipper	2.0
Direct or on L. S. Shaft of Reducer, with Final Drive:		Sorting Table	1.5	Cylinder, Dryer	1.75
Machined Spur Gears	2.0	Trimmer	1.75	Felt Stretcher	1.25
Single Helical or Herringbone Gears	1.75	MACHINE TOOLS		Fourdrinier	1.75
Crushers, Ore, or Stone	2.5	Auxiliary and Traverse Drive	1.0	Jordan	2.0
Dryer, Rotary	1.75	Bending Roll, Notching Press,		Log Haul	2.0
Grizzly	2.0	Punch Press, Planer, Plate Reversing	1.75	Line Shaft	1.5
Hammermill or Hog	1.75	Main Drive	1.5	Press	1.75
Tumbling Mill or Barrel	1.75	METAL FORMING MACHINES		Pulp Grinder	1.75
AGITATORS		Draw Bench Carriage and Main Drive	2.0	Reel, Reqinder, Winder	1.5
Vertical and Horizontal Screw		Extruder	2.0	Stock Chest, Washer, Thickener	1.5
Propeller Paddle	1.0	Forming Machine and Forming Mills	2.0	Stock Pumps, Centrifugal	
BADGE HAUL PULLER	1.5	Slitters	1.0	Constant Speed	1.0
BLOWERS		Wire Drawing or Flattening	1.75	Frequent Speed Changes Under Load	1.25
Centrifugal	1.0	Wire Winder	1.5	Suction Roll	1.75
Lobe or Vane	1.25	Coliers and Uncoilers	1.5	PRESS, PRINTING	1.5
BREWING and DISTILLING		METAL ROLLING MILLS		PUG MILL	1.75
Bottle and Can Filling Machines	1.0	Hot Mills-		PULVERIZERS	
Brew Kettle	1.0	Strip or Sheet Mills,		Hammermill and Hog	1.75
Cookers, Continuous Duty	1.25	Reversing Blooming, or Slabbing Mills	2.5	Roller	1.5
Lauter Tub	1.5	Edger Drives	1.5	PUMPS	
Mash Tub	1.25	Cold Mills-		Centrifugal-	
Scale Hopper, Frequent Peaks	1.75	Strip Mills, Temper Mills	2.0	Constant Speed	1.0
CAR DUMPERS	2.5	Rod Mills	2.0	Frequent Speed Changes Under Load	1.25
CAR PULLERS	1.5	Reel Drives	1.75	Descaling, with Accumulators	1.25
CLARIFIER or CLASSIFIER	1.0	Screwdown	2.0	Gear, Rotary, or Vane	1.25
CLAY WORKING INDUSTRY		Manipulators	3.0	Reciprocating-	
Brick Press, Briquette Machine, Clay Working		Sideguards	3.0	1 Cylinder-Single or Double Acting	3.0
Machine, Pug Mill*	1.75	Feed Rolls-Blooming Mills	3.0	2 Cylinders-Single Acting	2.0
COMPRESSORS		Ingot Cars	2.0	2 Cylinders-Double Acting	1.75
Centrifugal	1.0	Soaking Pit Cover Drives-		3 or More Cylinders	1.5
Rotary, Lobe, or Vane	1.25	Lift	1.0	RUBBER INDUSTRY	
Rotary Screw	1.0	Travel	2.0	Calender	2.0
Reciprocating-		Furnace Pushers	2.0	Cracker, Plasticator	2.5
With Flywheel and Gear Between		Cooling Beds	1.5	Extruder	1.75
Compressor and Prime Mover**		Straighteners	2.0	Intensive or Banbury Mixer	2.5
1 Cylinder-Single Acting	3.0	Unscramblers (Billet Bundle Busters)	2.0	Mixing Mill, Refiner, or Sheeter	
1 Cylinder-Double Acting	3.0	Hot and Cold Saws	2.0	One or Two in Line	2.5
2 Cylinders-Single Acting	3.0	Coilers (Up or Down) Hot Mills Only	2.0	Three or Four in Line	2.0
2 Cylinders-Double Acting	3.0	Coilers (Up or Down) Cold Mills Only	1.5	Five or More in Line	1.75
3 Cylinders-Single Acting	3.0	Slitters, Steel Mill Only	1.75	Tire Building Machine	2.5
3 Cylinders-Double Acting	2.0	Wire Drawing Machinery	1.75	Tire and Tube Press Opener (Peak Torque)	1.0
4 or More Cylinders-Single Acting	1.75	Drawbench	2.0	Tuber, Strainer, Pelletizer	1.75
4 or More Cylinders-Double Acting	1.75	Mill Tables		Warming Mill	
CONVEYORS		Roughing Breakdown Mills	3.0	One or Two Mills in Line	2.0
Apron, Assembly, Belt, Chain, Flight Screw	1.0	Hot Bed or Transfer, Non-Reversing	1.5	Three or More Mills in Line	1.75
Bucket	1.25	Runout, Reversing	3.0	Washer	2.5
Live Roll, Shaker, and Reciprocating	3.0	Runout, Non-Reversing, Non-Plugging	2.0	SCREENS	
CRANES and HOISTS		Seamless Tube Mills		Air Washing	1.0
Main Hoist	1.75	Piercer	3.0	Grizzly	2.0
Skip Hoist	1.75	Thrust Block	2.0	Rotary Coal or Sand	1.5
Slope	1.5	Tube Conveyor Rolls	2.0	Vibrating	2.5
Bridge, Travel or Trolley	1.75	Reeler	2.0	Water	1.0
DREDGES		Kick Out	2.0	SEWAGE DISPOSAL EQUIPMENT	
Cable Reel	1.75	Coke Plants		Bar Screen, Chemical Feeders, Collectors,	
Conveyors	1.25	Pusher Ram Drive	2.5	Dewatering Screen, Grit Collector	1.0
Cutter Head, Jig Drive	2.0	Door Opener	2.0	STEERING GEAR	1.0
Maneuvering Winch	1.5	Pusher or Larry Car Traction Drive	3.0	STOKER	1.0
Pumps (Uniform Load)	1.5	MIXERS (See Agitators)		SUGAR INDUSTRY	
Screen Drive, Stackler	1.75	Concrete	1.75	Cane Carrier and Leveler	1.75
Utility Winch	1.5	Muller	1.5	Cane Knife and Crusher	2.0
DYNAMOMETER	1.0	OIL INDUSTRY		Mill Stands, Turbine Driven with All Helical	
ELEVATORS		Chiller	1.25	or Herringbone Gears	1.5
Bucket, Centrifugal Discharge	1.25	Oil Well Pumping	2.0	Electric Drive or Steam Engine Drive with	
Gravity Discharge	1.25	Paraffin Filter Press	1.5	Helical, Herringbone, or Spur Gears with	
EXCITER, GENERATOR	1.0	Rotary Kiln	2.0	Any Prime Mover	1.75
EXTRUDER, PLASTIC	1.5	PAPER MILLS		TEXTILE INDUSTRY	
FANS		Barker Auxiliary, Hydraulic	2.0	Batcher	1.25
Centrifugal	1.0	Barker, Mechanical	2.0	Calender, Card Machine	1.5
Cooling Tower	2.0	Barking Drum		Cloth Finishing Machine	1.5
Forced Draft Across the Line Start	1.5	L.S. Shaft of Reducer with Final		Dry Can, Loom	1.5
Forced Draft Motor Driven thru Fluid		Drive-Helical or Herringbone Gear	2.0	Dyeing Machinery	1.25
or Electric Slip Clutch	1.0	Machined Spur Gear	2.5	Mangle, Napper, Soaper	1.25
Gas Recirculating	1.5	Cast Tooth Spur Gear	3.0	Spinner, Tenter Frame, Winder	1.5
Induced Draft with Damper Control or		Beater and Pulper	1.75	TUMBLING BARREL	1.75
Blade Cleaner	1.25	Bleachers, Coaters	1.0	WINCH, MANEUVERING	
Induced Draft without Controls	2.0	Calender and Super Calender	1.75	Dredge, Marine	1.5
FEEDERS		Chipper	2.5	WINDLASS	1.5
Apron, Belt, Disc, Screw	1.0			WOODWORKING MACHINERY	1.0
Reciprocating	2.5				

## System Service Factor (SF) Calculation

To determine the system SF, the Driver Service Factor adder must be added to the driven SF.

Example: determine the system SF for a Gear Coupling used to couple a barking drum with machined spur gear and a six-cylinderdiesel engine driven SF + Driver SF Adder = System SF, 2.5 + .5 = 3.0 The service factors listed are intended only as a general guide. Where substantial shock occurs, or where starting and stopping is frequent as on some "inching" drives and on some reversing drives, or where the power source is an internal combustion engine with less than four cylinders-consult DODGE. Where torsional vibrations occur as with an internal combustion engine or in reciprocating compressor or pump applications, check the coupling stiffness for the possible development of damaging large-amplitude vibrations. A complete system torsional analysis may be necessary.

◆ Consult DODGE for selection assistance.

\*\* Add 0.5 to factor if without flywheel.

Type of Coupling	Electric Motor Std Torque	High Torque Motors	Turbines	Reciprocating Engine Number of Cylinders				
				12 or more	8 to 11	6 to 7	4 to 5	Less than 4
Gear	0.0	0	0.0	0.0	0.5	0.5	1.0	◆

# Dimensions

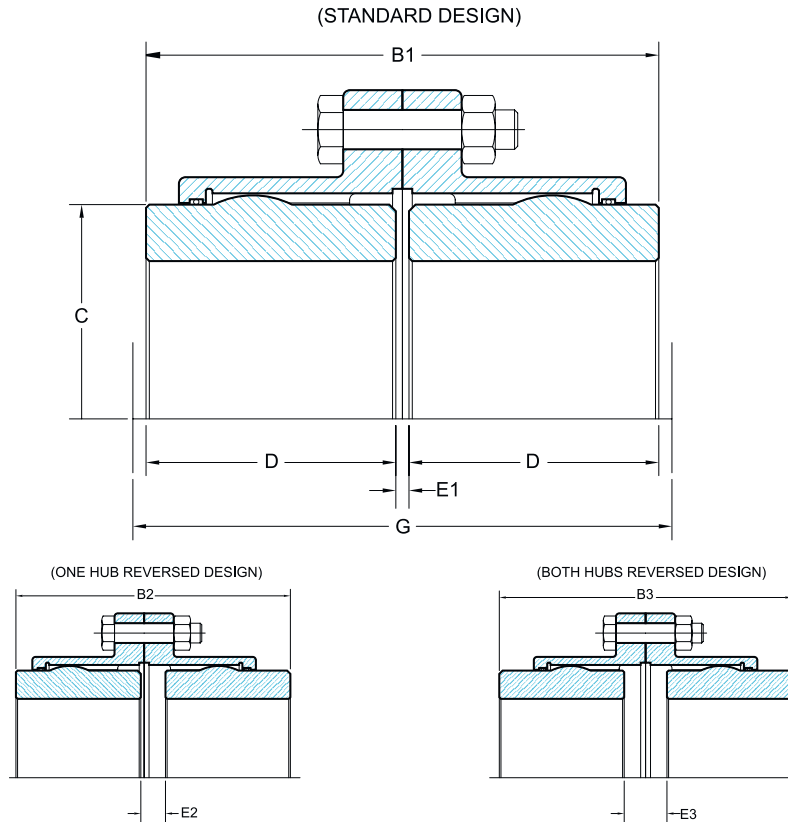

## DODGE Gear Coupling (DGF)

Size	Min. Bore (in.)	Max. Bore (in.) Standard Keyway		Max. Bore (in.) Shallow Keyway		HP/100 <sup>†</sup> RPM	Torque <sup>†</sup> (lbs.-in.)	Max RPM <sup>*</sup>	Max. Parallel Offset (in.) <sup>**</sup>	Approx. Weight (lbs.) <sup>***</sup>
		Flex Hub	Rigid Hub	Flex Hub	Rigid Hub					
1	0.438	1.625	2.188	1.750	2.313	12	7500	6000	0.055	9
1.5	0.438	2.125	2.813	2.250	3.063	30	18900	5500	0.060	19
2	0.563	2.750	3.500	3.000	3.750	50	31500	5000	0.085	34
2.5	0.813	3.250	4.250	3.375	4.500	90	56700	4400	0.105	55
3	1.188	4.000	4.875	4.250	5.250	150	94500	4000	0.115	86
3.5	1.563	4.625	5.625	4.875	6.125	240	151300	3500	0.130	135
4	1.813	5.500	6.500	5.625	6.875	350	220600	3000	0.150	195
4.5	1.813	6.000	7.375	6.438	8.000	480	302500	2700	0.175	268
5	2.563	6.875	8.375	7.000	8.875	690	434900	2500	0.200	394
5.5	3.063	7.750	9.250	7.875	9.875	910	573500	2200	0.220	526
6	4.063	8.625	10.125	8.750	11.000	1190	750000	2100	0.120	687
7	5.563	9.500	11.250	9.750	12.250	1600	1008400	2000	0.135	1017

<sup>†</sup> Ratings are based on standard interface fit

<sup>\*</sup> For higher RPM applications, contact DODGE

<sup>\*\*</sup> Based on 1-1/2 degrees angular misalignment per gear mesh for sizes 1 through 5-1/2, 3/4 degree angular misalignment per gear mesh for sizes 6 and 7, and maximum bore. Flex-Rigid configurations do not accept parallel misalignment.

<sup>\*\*\*</sup> Approximate weight with minimum bore.

Size	Dimension (in.)									
	B1	B2	B3	C	D	E1	E2	E3	G*	
1	3 1/2	3 13/16	4 1/8	2 5/16	1 11/16	1/8	7/16	3/4	4 3/16	
1.5	4	4 1/4	4 1/2	3	1 15/16	1/8	3/8	5/8	4 3/4	
2	5	5 13/16	6 3/8	4	2 7/16	1/8	13/16	1 1/2	6	
2.5	6 1/4	7 1/32	7 13/16	4 5/8	3 1/32	3/16	31/32	1 3/4	7 1/8	
3	7 3/8	8 1/32	8 11/16	5 5/8	3 19/32	3/16	27/32	1 1/2	8 1/8	
3.5	8 5/8	9 3/16	9 3/4	6 1/2	4 3/16	1/4	13/16	1 3/8	9 3/8	
4	9 3/4	10 7/16	11 1/8	7 1/2	4 3/4	1/4	15/16	1 5/8	10 1/4	
4.5	10 15/16	12	13 1/16	8 1/2	5 5/16	5/16	1 3/8	2 7/16	11 1/2	
5	12 3/8	13 23/32	15 1/16	9 1/2	6 1/32	5/16	1 21/32	3	13	
5.5	14 1/8	15 5/8	17 1/8	6 29/32	6 29/32	5/16	1 13/16	3 5/16	14 3/8	
6	15 1/8	16 17/32	17 15/16	11 1/2	7 13/32	5/16	1 23/32	3 1/8	17	
7	17 3/4	19 1/16	20 3/8	13	8 11/16	3/8	1 11/16	3	20	

\* Minimum space required to install and align coupling

(FLANGED SLEEVE AND RIGID HUB DETAILS)

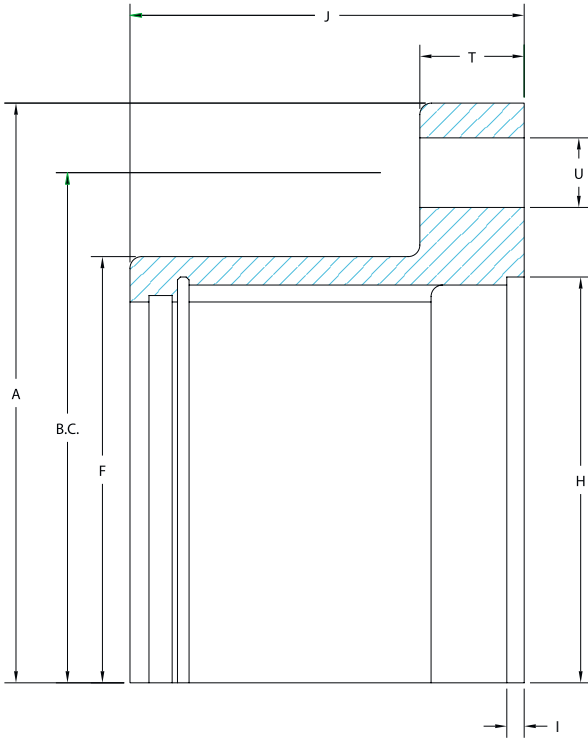

Size	Outside Diameter A	Flange Width J	Flange Thickness T	Hub Diameter F	Undercut Depth I	Undercut Diameter H	Hole Diameter H	Bolt Circle B.C.	Number of Bolts
	All Dimensions in Inches								
1	4 9/16	1 21/32	9/16	3	3/32	2 7/8	1/4	3 3/8	6
1.5	6	1 7/8	3/4	3 7/8	3/32	3 11/16	3/8	4 13/16	8
2	7	2 3/8	3/4	4 13/16	3/32	4 5/8	1/2	5 7/8	6
2.5	8 3/8	2 7/8	15/16	5 13/16	3/32	5 7/16	5/8	7 1/8	6
3	9 7/16	3 5/16	15/16	6 13/16	3/32	6 7/16	5/8	8 1/8	8
3.5	11	3 13/16	1 1/8	7 27/32	3/32	7 3/8	3/4	9 1/2	8
4	12 1/2	4 1/4	1 1/8	9 3/16	3/16	8 3/4	3/4	11	8
4.5	13 5/8	4 13/16	1 1/8	10 5/16	3/16	9 3/4	3/4	12	10
5	15 5/16	5 1/2	1 1/2	11 7/16	3/16	10 3/4	7/8	13 1/2	8
5.5	16 3/4	6	1 1/2	10 1/2	3/16	12 1/8	7/8	14 1/2	14
6	18	6 11/16	1	13 15/16	3/16	13 3/8	7/8	15 3/4	14
7	20 3/4	7 3/8	1 1/8	15 3/4	1/4	14 5/8	1	18 1/4	16









## Part Numbers

Part Number	Description	Part Number	Description	Part Number	Description
<b>Size 1.0</b>		<b>Size 3.0</b>		<b>Size 5.0</b>	
013110	DGF 1.0 FLEX HUB	013126	DGF 3.0 FLEX HUB	013142	DGF 5.0 FLEX HUB
013111	DGF 1.0 SLEEVE EB	013127	DGF 3.0 SLEEVE EB	013143	DGF 5.0 SLEEVE EB
013112	DGF 1.0 RIGID HUB EB	013128	DGF 3.0 RIGID HUB EB	013144	DGF 5.0 RIGID HUB EB
013113	DGF 1.0 HARDWARE KIT	013129	DGF 3.0 HARDWARE KIT	013145	DGF 5.0 HARDWARE KIT
<b>Size 1.5</b>		<b>Size 3.5</b>		<b>Size 5.5</b>	
013114	DGF 1.5 FLEX HUB	013130	DGF 3.5 FLEX HUB	013146	DGF 5.5 FLEX HUB
013115	DGF 1.5 SLEEVE EB	013131	DGF 3.5 SLEEVE EB	013147	DGF 5.5 SLEEVE EB
013116	DGF 1.5 RIGID HUB EB	013132	DGF 3.5 RIGID HUB EB	013148	DGF 5.5 RIGID HUB EB
013117	DGF 1.5 HARDWARE KIT	013133	DGF 3.5 HARDWARE KIT	013149	DGF 5.5 HARDWARE KIT
<b>Size 2.0</b>		<b>Size 4.0</b>		<b>Size 6.0</b>	
013118	DGF 2.0 FLEX HUB	013134	DGF 4.0 FLEX HUB	013150	DGF 6.0 FLEX HUB
013119	DGF 2.0 SLEEVE EB	013135	DGF 4.0 SLEEVE EB	013151	DGF 6.0 SLEEVE EB
013120	DGF 2.0 RIGID HUB EB	013136	DGF 4.0 RIGID HUB EB	013152	DGF 6.0 RIGID HUB EB
013121	DGF 2.0 HARDWARE KIT	013137	DGF 4.0 HARDWARE KIT	013153	DGF 6.0 HARDWARE KIT
<b>Size 2.5</b>		<b>Size 4.5</b>		<b>Size 7.0</b>	
013122	DGF 2.5 FLEX HUB	013138	DGF 4.5 FLEX HUB	013154	DGF 7.0 FLEX HUB
013123	DGF 2.5 SLEEVE EB	013139	DGF 4.5 SLEEVE EB	013155	DGF 7.0 SLEEVE EB
013124	DGF 2.5 RIGID HUB EB	013140	DGF 4.5 RIGID HUB EB	013156	DGF 7.0 RIGID HUB EB
013125	DGF 2.5 HARDWARE KIT	013141	DGF 4.5 HARDWARE KIT	013157	DGF 7.0 HARDWARE KIT

### Ordering Information: Standard Gear Couplings may be orders in 3 different assemblies -

- Flex-Flex (or Full Flex) :: To order a complete Flex-Flex coupling you need - (2) Flex Hubs [re-borable], (2) Sleeves (includes Seal), and (1) Hardware Kit.
- Flex-Rigid :: To order a complete Flex-Rigid Coupling you need - (1) Flex Hub [re-borable], (1) Sleeve (includes Seal), (1) Rigid Hub [re-borable], and (1) Hardware Kit.
- Rigid-Rigid :: To order a complete Rigid-Rigid Coupling you need - (2) Rigid Hubs [re-borable], and (1) Hardware Kit.

DODGE	Falk G20 Seies	Kop-Flex KoppersH Series	Amerigear ZurnF Series	Lovejoy/Sier-Bath
1	1010	1H	201	-
1.5	1015	1 1/2 H	201 1/2	1.5
2	1020	2H	202	2
2.5	1025	2 1/2 H	202 1/2	2.5
3	1030	3H	203	3
3.5	1035	3 1/2 H	203 1/2	3.5
4	1040	4H	204	4
4.5	1045	4 1/2 H	204 1/2	4.5
5	1050	5H	205	5
5.5	1055	5 1/2 H	205 1/2	5.5
6	1060	6H	206	6
7	1070	7H	207	-

Coupling							 
<b>Selection Criteria</b>							
Misalignment							Better alignment provides longer life and lowers the reaction forces imposed on bearings. In all situations, misalignment should be minimized as much as possible.
Temperature Range							Rubber seals and elastomeric elements are generally the most heat limited coupling component. Also, most nonsynthetic lubricants should not be used much above 220°F.
Torque-Bore Capability							This relationship describes torque and bore capabilities relative to the physical size of the coupling. This consideration may be important if the coupling must operate in a limited space.
Speed Capability							As the diameter of a coupling increases, its speed capability decreases due to centrifugal forces exerted on materials. Further, couplings with all-machined parts can operate at higher speeds.
Torsionally Soft							Generally allows application wind-up to cushion shock loads and vibration. "Soft" coupling helps protect motor and reducer from shock loads in the driven equipment.
Installation Cost							Account of initial installation cost including equipment requirements, difficulty, alignment time, and manpower.
Ease of Maintenance							Based on frequency and difficulty of routine parts or coupling replacement, lubrication, or other scheduled maintenance.
Repair Cost							Based on cost and difficulty of replacement of a failing or failed coupling.

[www.rockwellautomation.com](http://www.rockwellautomation.com)
[www.ptplace.com](http://www.ptplace.com)
[www.dodge-pt.com](http://www.dodge-pt.com)
[www.reliance.com](http://www.reliance.com)
[www.ptplace.com](http://www.ptplace.com)

**Corporate Headquarters**

Rockwell Automation, 777 East Wisconsin Avenue, Suite 1400, Milwaukee, WI, 53202-5302 USA, Tel: (1) 414.212.5200, Fax: (1) 414.212.5201

**Headquarters for Dodge and Reliance Electric Products**

Americas: Rockwell Automation, 6040 Ponders Court, Greenville, SC 29615-4617 USA, Tel: (1) 864.297.4800, Fax: (1) 864.281.2433  
 Europe/Middle East/Africa: Rockwell Automation, Brhlstraße 22, D-74834 Elztal-Dallau, Germany, Tel: (49) 6261 9410, Fax: (49) 6261 17741  
 Asia Pacific: Rockwell Automation, 55 Newton Road, #11-01/02 Revenue House, Singapore 307987, Tel: (65) 6356-9077, Fax: (65) 6356-9011

**Headquarters for Allen-Bradley Products, Rockwell Software Products and Global Manufacturing Solutions**

Americas: Rockwell Automation, 1201 South Second Street, Milwaukee, WI 53204-2496 USA, Tel: (1) 414.382.2000, Fax: (1) 414.382.4444  
 Europe/Middle East/Africa: Rockwell Automation SA/NV, Vorstlaan/Boulevard du Souverain 36, 1170 Brussels, Belgium, Tel: (32) 2 663 0600, Fax: (32) 2 663 0640  
 Asia Pacific: Rockwell Automation, 27/F Citicorp Centre, 18 Whitfield Road, Causeway Bay, Hong Kong, Tel: (852) 2887 4788, Fax: (852) 2508 1846

DMR-1720-3

9/02-5M-K

This material is not intended to provide operational instructions. Appropriate Rockwell Automation instruction manuals and precautions should be studied prior to installation, operation or maintenance of equipment.

Copyright © 2002 Rockwell Automation. All rights reserved. Printed in USA.  
 DODGE, RELIANCE ELECTRIC, D-FLEX, GRID-LIGN, PTWIZARD, and TAPER-LOCK are trademarks of Rockwell Automation.