

JUBOFLEX® elastic coupling

Description

JUBOFLEX® couplings are made of:

- one elastic element made of pre-compressed, natural rubber, reinforced with steel to be fitted with fixing screws and a metallic band (to be removed after mounting);
- two metallic hubs made of forged steel (size 120 produced in cast iron).

They are produced:

- for mounting with SER-SIT® taper bushing from size 4 to 25;
- solid hub from size 35 to 120.

GJB4 - GJB25

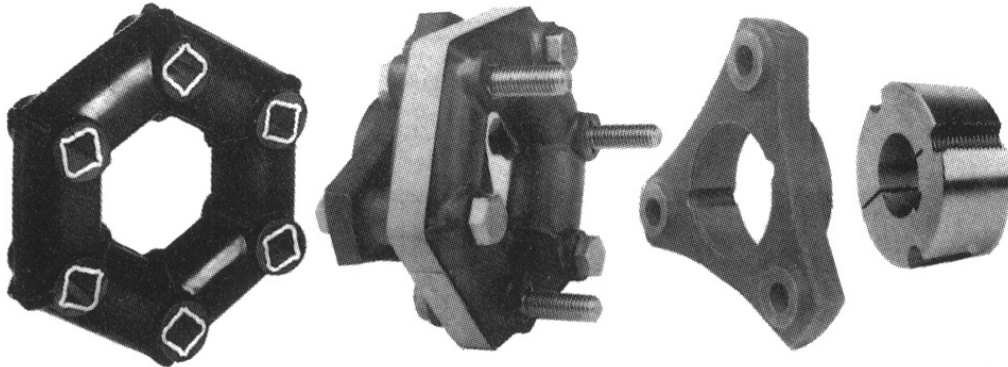

GJ4 - GJ120

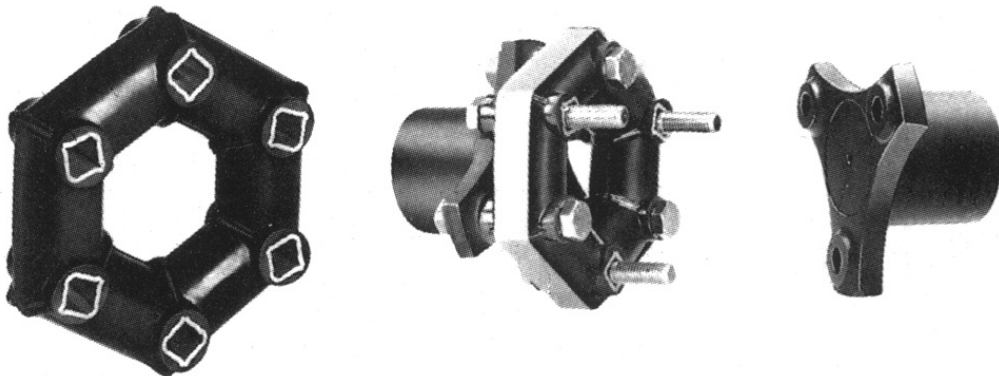

Features

JUBOFLEX® coupling has exceptional elastic properties. In fact, it allows for:

- an excellent dampening effect of the load peaks;
- high safety factor and a very high resistance to alternating deformation, thanks to pre-compression;
- possibility of bearing misalignment values rarely possible with other couplings.

In this way it avoids the need of a precise alignment of the machines to be coupled. It is recommended to remove the metallic band of the elastic element after the coupling is mounted; pre-compression will be assured by the fixing screws.

Coding

Codification of the JUBOFLEX® couplings is:

- GJ complete coupling solid hub;
- GJM hub;
- AJ elastic element.

To identify the desired size use the nominal torque of the coupling.

E.G.: GJ4 = complete coupling (2 hubs + 1 elastic element) with nominal torque of 40 Nm.

JUBOFLEX® elastic coupling - solid hub

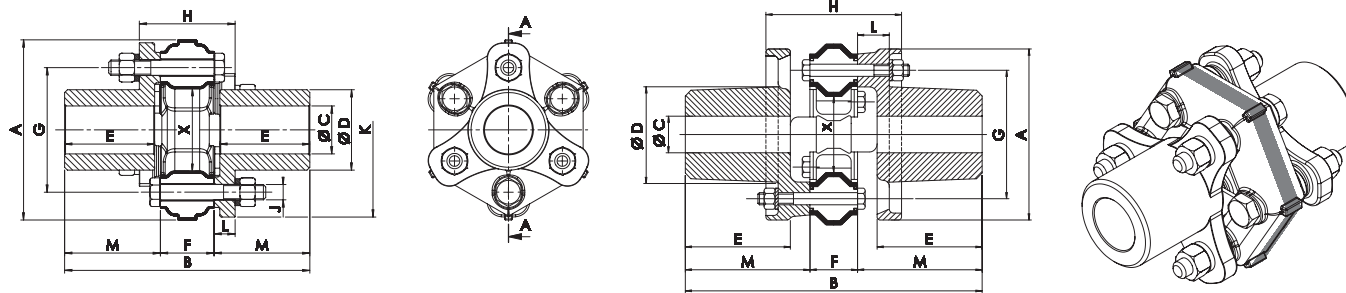

GJ4 - GJ70

GJ120

Size	C		A [mm]	B [mm]	D [mm]	E [mm]	F [mm]	G [mm]	H [mm]	J [mm]	K [mm]	L [mm]	M [mm]	X [mm]	W [kg]
	min [mm]	max [mm]													
GJ4	-	30	91	128	42	47	28	65	50	8	87	11	50	23	2
GJ9	-	40	117	172	56	66	32	85	60	10	113	14	70	35	3
GJ16	-	48	142	196	68	70	46	100	80	12	135	17	75	40	5
GJ25	-	60	181	247	90	93	51	132	93	14	172	21	98	63	12
GJ35	-	70	202	284	105	109	54	150	96	18	196	21	115	68	18
GJ50	-	75	232	322	115	124	62	170	108	20	225	23	130	75	25
GJ70	-	80	263	346	122	133	68	190	116	20	246	24	139	82	32
GJ120*	60	100	280	486	156	172	78	210	222	20	-	52	204	110	57

*= 8 lobes execution

JUBOFLEX® elastic coupling for mounting SERSIT® taper bushing

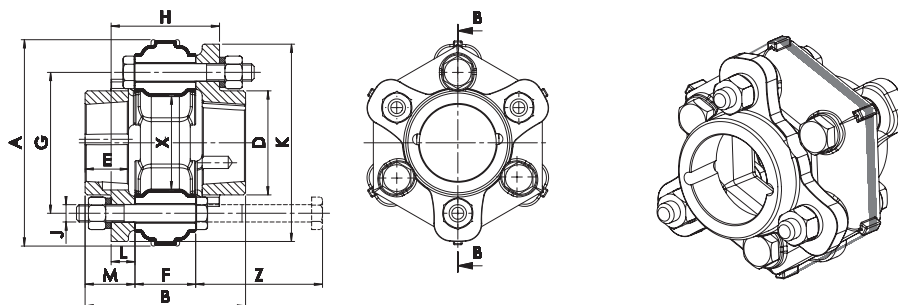

Size	SER-SIT® taper bushing	A [mm]	B [mm]	D [mm]	E [mm]	F [mm]	G [mm]	H [mm]	J [mm]	K [mm]	L [mm]	M [mm]	X [mm]	W [mm]	Z [mm]
GJB4	1108	91	74	48	20	28	65	54	8	91	11	23	23	0,8	65
GJB9	1210	117	90	60	25	32	85	65	10	121	14	29	35	1,6	75
GJB16	1610	142	106	70	25	46	100	81	12	140	17	30	40	2,7	90
GJB25	2012	181	121	95	30	51	132	91	14	177	21	35	63	5	100

SERSIT® taper bushing

Type	Diameter of the bore (H7) Keyway according to DIN 6885 sheet 1 - JS9	Length [mm]	Diam. max.	Screws				Ms [Nm]
				n°	withworth	Length [mm]	Sets screws wrench type	
1108 (28.20)	[mm] 9 10 11 12 14 15 16 18 19 20 22 24 25 26 27 28	22,3	38	2	1/4	13	M3	5,5
	[inches] 3/8 - 1/2 - 5/8 - 3/4 - 7/8 - 1 - 1 1/8							
1210 (30.25)	[mm] 11 12 14 15 16 18 19 20 22 24 25 26 28 30 32	25,4	47	2	3/8	16	M5	20
	[inches] 1/2 - 5/8 - 3/4 - 7/8 - 1 - 1 1/8 - 1 1/4							
1610 (40.25)	[mm] 12 14 15 16 18 19 20 22 24 25 26 28 30 32 35 38 40 42	25,4	57	2	3/8	16	M5	20
	[inches] 3/8 - 1/2 - 5/8 - 3/4 - 7/8 - 1 - 1 1/8 - 1 1/4 - 1 3/8 - 1 1/2 - 1 5/8							
2012 (50.30)	[mm] 14 15 16 18 19 20 22 24 25 26 28 30 32 35 38 40 42 45 48 50	31,8	70	2	7/16	22	M5	20
	[inches] 5/8 - 3/4 - 7/8 - 1 - 1 1/8 - 1 1/4 - 1 3/8 - 1 1/2 - 1 5/8 - 1 3/4 - 1 7/8 - 2							

Bore diameters in bold type are made in steel instead of cast iron.

Technical Data

Size	T _{KN} [Nm]	T _{Kmax} [Nm]	φ [°]	n _{max} [min ⁻¹]	Nr	Screws/ Type
GJ4	40	120	8	6.000	6	M8 x 50
GJ9	90	270	8	5.000	6	M10 x 65
GJ16	160	480	8	4.500	6	M12 x 80
GJ25	250	750	7	3.500	6	M14 x 90
GJ35	350	1050	7	3.000	6	M18 x 100
GJ50	500	1500	7	2.800	6	M20 x 115
GJ70	700	2100	8	2.400	6	M20 x 115
GJ120	1200	3600	6,5	2.400	8	M20 x 150

T _{KN}	Coupling nominal torque	Nm
T _{Kmax}	Coupling maximum torque	Nm
φ	Torsion angle	°
n _{max}	Maximum rpm	min ⁻¹
Nr	Number of screws	

Order form

Hub **GJM 16**

GJM: JUBOFLEX® solid hub
GJMB: JUBOFLEX® for mounting SER-SIT® taper bushing

Size

Elastic element **AJ 16**

AJ: elastic element

Size

Power Rating

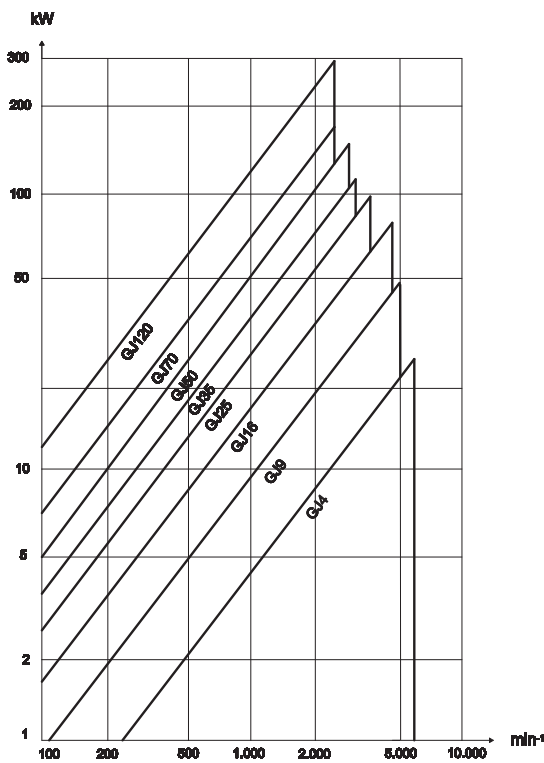

Radial Misalignment

Nominal torque [Nm]	Radial misalignment 1.500 rpm [mm]
40	0,7
90	0,9
160	1,4
250	1,5
350	1,8
500	2
700	2,1
1200	2,4

Angular Misalignment

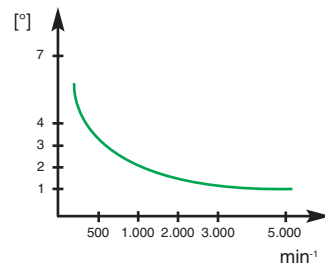

Mounting

The precompression, for the initial mounting, is achieved by securing the metallic band around the elastic element (all elements are supplied with metallic band of precompression).

To mount the coupling, tighten the three screws not adjacent to the bores of the elastic element to the three arms of one hub and the three remaining bores of the elastic element to the other hub.

Tighten the screws with the torques indicated in the table. Cut the metallic band when coupling is mounted.

Size	Ms [Nm]
GJ4	21
GJ9	41
GJ16	72
GJ25	113
GJ35	240
GJ50	350
GJ70	350
GJ120	350